

**Butterfly valve with Lug types**

- For open and closed cold and warm water systems
- For switching heat generators or cooling machines on/off

**Type overview**

| Type           | DN<br>[ ] | DN<br>[“] | kvmax<br>[ m <sup>3</sup> /h] | kvs<br>[ m <sup>3</sup> /h] | PN<br>[ ] |
|----------------|-----------|-----------|-------------------------------|-----------------------------|-----------|
| <b>D6200WL</b> | 200       | 8         | 2200                          | 820                         | 16        |
| <b>D6250WL</b> | 250       | 10        | 4200                          | 1300                        | 16        |
| <b>D6300WL</b> | 300       | 12        | 5700                          | 1740                        | 16        |

**Technical data**

|                        |                                   |  |
|------------------------|-----------------------------------|--|
| <b>Functional data</b> | Fluid                             | Cold and warm water, water with glycol up to max. 50% vol.   |
|                        | Fluid temperature                 | -20...120 °C   |
|                        | Permissible operating pressure ps | 1600 kPa   |
|                        | Leakage rate                      | tight, leakage rate A (EN 12266-1)   |
|                        | Angle of rotation                 | 90°  |
|                        | Installation position             | upright to horizontal (in relation to the stem)  |
|                        | Suitable connection flange        | In accordance with ISO 7005-1 and EN 1092-1<br>In accordance with ISO 7005-2 and EN 1092-2<br>In accordance with DIN 2641 and DIN 2642 |
| <b>Materials</b>       | Servicing                         | maintenance-free   |
|                        | Housing                           | EN-GJS-400-15 (GGG 40), polyester-powder coating   |
|                        | Closing element                   | stainless steel (1.4308)   |
|                        | Stem                              | stainless steel AISI 420 (1.4021)  |
|                        | Stem seal                         | EPDM O-ring  |
|                        | Stem bearing                      | Bronze, steel, PTFE  |
|                        | Seat                              | EPDM   |

**Safety notes**

- The valve has been designed for use in stationary heating, ventilation and air-conditioning systems and must not be used outside the specified field of application, especially in aircraft or in any other airborne means of transport.
- Only authorised specialists may carry out installation. All applicable legal or institutional installation regulations must be complied during installation.
- The valve does not contain any parts that can be replaced or repaired by the user.
- The valve may not be disposed of as household refuse. All locally valid regulations and requirements must be observed.
- When determining the flow rate characteristic of controlled devices, the recognised directives must be observed.
- The damper must be opened and closed slowly in order to avoid hydraulic shocks in the pipe system.
- The valve is not allowed to be operated without actuator or worm gear while flow is in the pipe. Without actuator or worm gear, the valve could close and cause damage (water hammer).

## Product features

- Mode of operation** The butterfly valve is opened or closed completely by an open/close rotary actuator. Continuous rotary actuators are connected by a commercially available controller and move the valve to any position desired. The valve disk made of stainless steel is pressed into the soft-sealing EPDM seat by a rotary movement and ensures leakage rate A (tight). The pressure losses are slight in the open position and the kv value is at a maximum.
- Manual override** Manual throttling or isolation can be carried out with a worm gear (see «Accessories»). The worm gear with position indication is steplessly adjustable (self-locking).

## Accessories

|                        | Description                                 | Type      |
|------------------------|---|-----------|
| Mechanical accessories | Worm gear for butterfly valves DN 125...300 | ZD6N-S150 |

## Installation notes

- Recommended installation positions** The butterfly valves may be mounted upright to horizontal. The butterfly valves may not be installed in a hanging position i.e. with the spindle pointing downwards.

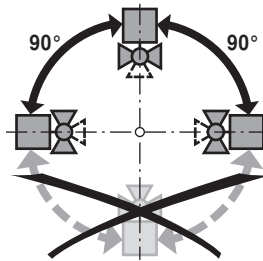

- Water quality requirements** The water quality requirements specified in VDI 2035 must be adhered to.

- Servicing** Butterfly valves and rotary actuators are maintenance-free. Before any service work on the final controlling device is carried out, it is essential to isolate the rotary actuator from the power supply (by unplugging the electrical cable if necessary). Any pumps in the part of the piping system concerned must also be switched off and the appropriate slide valves closed (allow all components to cool down first if necessary and always reduce the system pressure to ambient pressure level). The system must not be returned to service until the butterfly valve and the rotary actuator have been reassembled correctly in accordance with the instructions and the pipeline has been refilled by professionally trained personnel. To avoid a torque increase during off season shut down, exercise the butterfly valve (full open and close) at least once a month.

- Flow setting** The Belimo butterfly valves have an approximate equal percentage characteristic curve between 0...60% opening angle.

|        |                        | 10% | 20% | 30% | 40% | 50%  | 60%  | 70%  | 80%  | 90%  | 100% |
|--------|------------------------|-----|-----|-----|-----|------|------|------|------|------|------|
| DN 200 | kv (m <sup>3</sup> /h) | 10  | 60  | 170 | 330 | 540  | 820  | 1200 | 1640 | 2000 | 2200 |
| DN 250 | kv (m <sup>3</sup> /h) | 10  | 100 | 280 | 530 | 850  | 1300 | 1920 | 2710 | 3580 | 4200 |
| DN 300 | kv (m <sup>3</sup> /h) | 30  | 160 | 400 | 710 | 1130 | 1740 | 2560 | 3610 | 4790 | 5700 |



Table: Valve opening / flow

## Dimensions / Weight

Dimensional drawings

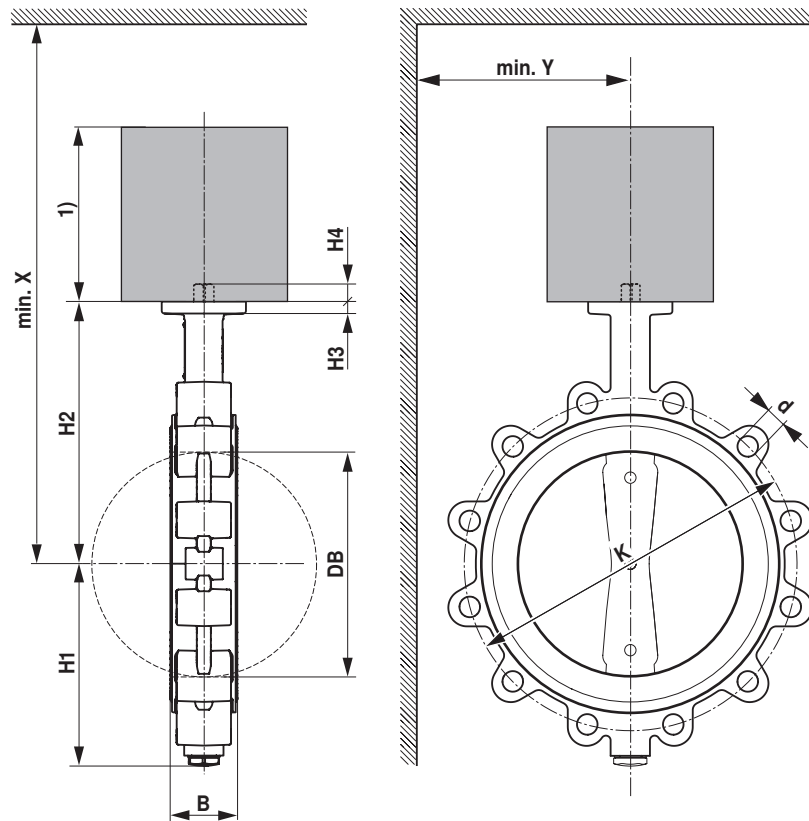

The actuator dimensions can be found on the respective actuator data sheet.

| Type    | DN<br>[ ] | B<br>[ mm] | DB<br>[ mm] | H1<br>[ mm] | H2<br>[ mm] | H3<br>[ mm] | H4<br>[ mm] | d (PN16)<br>[ mm] | K (PN16)<br>[ mm] | X<br>[ mm] | Y<br>[ mm] | Weight |
|---------|-----------|------------|-------------|-------------|-------------|-------------|-------------|-------------------|-------------------|------------|------------|--------|
| D6200WL | 200       | 60         | 195         | 175         | 260         | 15          | 19          | 12 x M20          | 295               | 500        | 300        | 16 kg  |
| D6250WL | 250       | 68         | 245         | 215         | 280         | 15          | 19          | 12 x M24          | 355               | 530        | 300        | 27 kg  |
| D6300WL | 300       | 78         | 293         | 247         | 325         | 15          | 19          | 12 x M24          | 410               | 580        | 300        | 43 kg  |

## Further documentation

- The complete product range for water applications
- Data sheets for actuators
- Installation instructions for actuators and/or butterfly valves
- General notes for project planning